



1100 Series

1106D-E66TA

Industrial Open Power Unit

168 kW (225 hp) @ 2200 rev/min

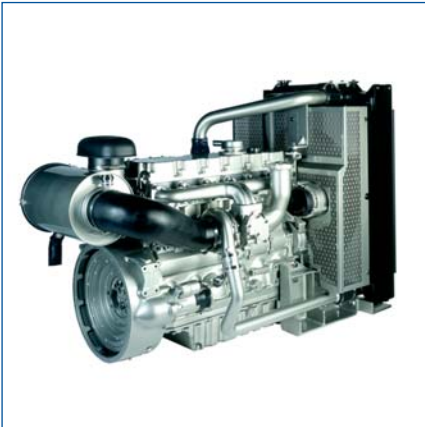

Powered by Your Needs

The Perkins 1106D-E66TA IOPU range offers a choice of ratings and standard build configurations to match the power needs of customers for a diverse range of applications.

State of the Art Design

The Perkins 1106D utilises components of Caterpillar ACERT™ technology. This provides excellent fuel economy and low heat rejection.

Worldwide Power Solution

The 1106D has been designed to be worldwide fuel tolerant, including kerosene, jet aviation fuel and 5% biofuel (RME). Options are available to meet local market needs.

World Class Product Support

At Perkins we are constantly researching, developing and investing in our products and services. Total worldwide support is provided through a network of 4000 distributors and service outlets, providing access to over 50,000 parts and exchange units 24 hours a day, 365 days a year. This support is enhanced by TIPSS (The Integrated Parts and Service System). TIPSS enables customers to electronically specify and order parts as well as service 1106D engines with online guides and service tools.

Lower Operating Costs

The 1106D maintains Tier 2 / Stage II fuel economy. Service intervals are set at 500 hours as standard and Perkins provides comprehensive warranty cover for 2 years (up to 3000 hours), with 3 years on major engine components. Low usage warranty package is also available.

Long Term Power Solution

The 1106D IOPU range has been designed to fully comply with stringent EPA Tier 3 / EU Stage IIIA emissions regulations for mobile applications, providing an emissions compliant power solution going forward.

Compliant to Tier 3 / Stage IIIA emissions, the 1106D-E66TA is the latest addition to the common platform concept of 1100 Series diesel engines. Assembled on a new high technology production line, this ultra clean engine will provide a superior replacement for the 1106C-E60TA Tier 2 / Stage II engine. Frequent computerised checks during the production process ensure high build quality excellence is maintained.

The new engine boasts considerable increases to delivered power, torque and noise reduction. These have been achieved through changes to the manifold and combustion areas, turbocharger geometry, increased cylinder displacement and significantly, the inclusion of a high pressure, common rail fuel system. This new engine incorporates components of Caterpillar ACERT™ technology.

Perkins new 1106D-E66TA IOPU range has a complete fuel system, air cleaner and radiator supplied as standard. Choice is provided to customers through the availability of a large variety of standard specifications incorporating a choice of fan, alternator, front PTO, and air compressor.

1100 Series

1106D-E66TA

Engine Specification

Air inlet

- Mounted air filter and turbocharger

Cooling system

- Fan (pusher or puller)
- Fan drive
- Radiator
- Water pump

Electric equipment

- Alternator (12 or 24 volt)
- Starter motor (12 or 24 volt)

Flywheel and housing

- Flywheel
- SAE 2 flywheel housing

Fuel system

- Fuel cooler
- Fuel filter

Literature

- User's Handbook

Lubrication system

- Oil cooler and filter
- Timing case oil filler

Mountings

- Engine mounting brackets

PTO

- SAE A or SAE B front PTO (142/280 Nm)

Start aids

- Glow plugs

IOPU Options

The 1106D-E66TA IOPU range offers a wide choice of standard build specifications to meet specific customer needs:

- 12 or 24 volt alternator
- Pusher or puller fan
- SAE A or SAE B front PTO
SAE B provides 63 kW/85 hp
- Air compressor

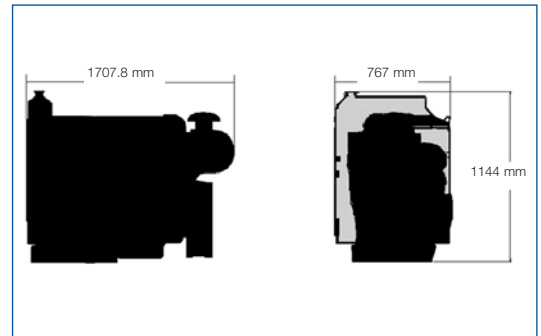

General Data

Number of cylinders	Vertical in-line 6 cylinder
Bore and stroke	105 mm x 127 mm
Displacement	6.6 litres
Aspiration	Turbocharged air-to-air aftercooling
Cycle	4 stroke
Combustion system	Direct injection
Compression ratio	16.2:1
Rotation	Anti-clockwise viewed on flywheel
Cooling system	Water
Dimensions	Length 1707.8 mm Width 767 mm Height 1144 mm
Dry weight	709 kg
Wet weight	752 kg

Height is above mounting feet. Length includes a fitted air cleaner
Final weight and dimensions will depend on completed specification

Rating	Net Intermittent* kW (hp)	Maximum Torque (Nm)
168 kW (225 hp) @ 2200 rpm	153.3 (205.6)	983

*Intermittent service: maximum power and/or speed are cyclic (time at full load not to exceed 50%)



Perkins Engines Company Limited

Peterborough PE1 5NA
United Kingdom
Telephone +44 (0)1733 583000
Fax +44 (0)1733 582240
www.perkins.com

All information in this document is substantially correct at time of printing and may be altered subsequently
Publication No.1801/11/05 Produced in England ©2005 Perkins Engines Company Limited

Distributed by